

# 4-Bar Clips

**Save Money With Complete Packages**

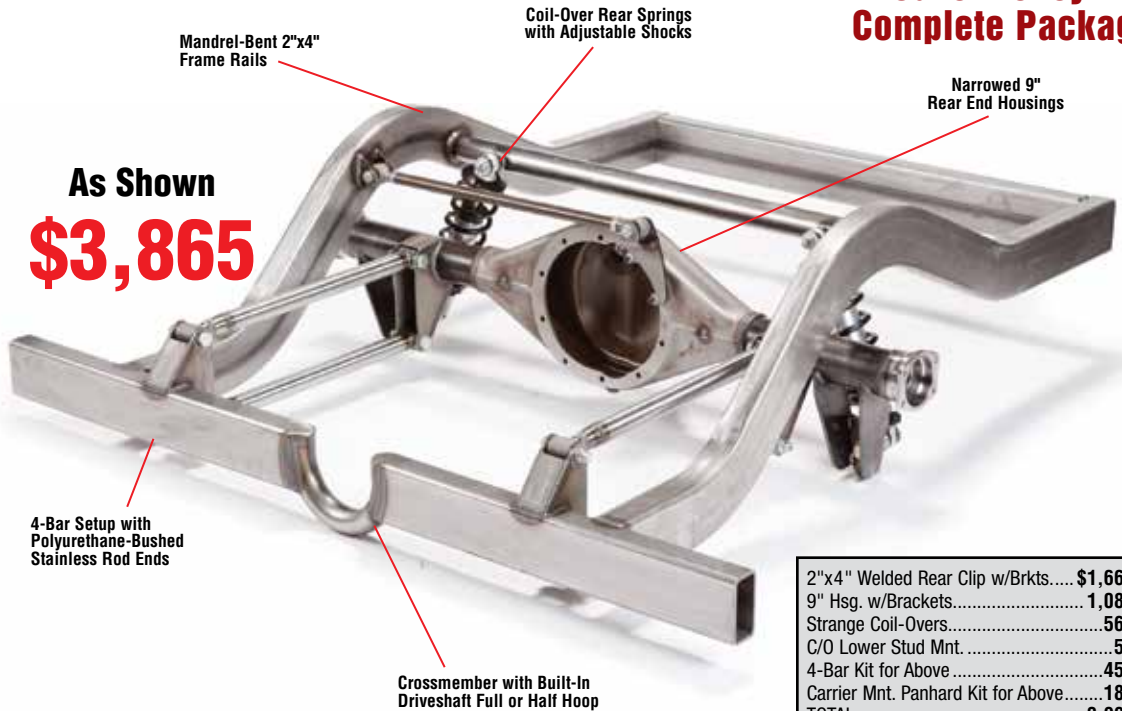

**As Shown**  
**\$3,865**

2"x4" Welded Rear Clip w/Brkts.....	\$1,660.00
9" Hsg. w/Brackets.....	1,080.00
Strange Coil-Overs.....	560.00
C/O Lower Stud Mnt.....	55.00
4-Bar Kit for Above.....	455.00
Carrier Mnt. Panhard Kit for Above.....	180.00
TOTAL.....	3,990.00
Package Discount.....	-125.00
<b>Package Price.....</b>	<b>\$3,865.00</b>

## 4-Bar Clip Package

For many applications —especially those with very tight quarters— the 4-bar suspension offers many advantages. Operating on the principle of a “constant motion parallelogram,” the design of the 4-bar is such that the rear end housing is always parallel to the ground—pinion angle never changes.

This, combined with the lateral stability of the Panhard bar, does an excellent job of locating the rear end and keeping it in proper alignment. You will note that the rear frame “kick up” of the 4-bar setup is far less severe than what is required for a 4-link or ladder bar suspension. This is beneficial for many street applications, where interior and trunk space is at a premium. Likewise, use of a 4-bar setup in a pickup truck will minimize the area wheel tubs encroach into the bed. It’s the hot setup for a low profile ride!

Morrison’s complete 4-bar clip assemblies include a 2"x4" (.120" wall) rectangular tube rear subframe that is CAD-engineered for the applications. Each is designed for the year/make/model vehicle to assure a correct fit and make for the optimum ease of installation. Moreover,

each subframe is precision fixture-welded by expert As to assure the proper alignment of chassis and suspension components.

The frame rails are mandrel-formed to assure a superb finish with “show quality” bends. The assembly comes with a driveshaft hoop and all suspension brackets. The 4-bar setup features

Morrison’s highly regarded polyurethane-bushed stainless steel rod ends and coil springs rate-matched to the application and coil-over shock absorbers.

Complete 9" rear end assemblies are also available. Don’t forget to ask your friendly Morrison salesman for extra savings when ordering parts.



4-Bar Kit.....	\$495.00
Strange Coil-Overs.....	560.00
C/O Lower Mount Kit.....	160.00
Crsmbr. & Upper Mkts.....	70.00
Carrier Mnt. Panhard Kit.....	180.00
TOTAL.....	1,465.00
Package Discount.....	-50.00
<b>Package Price.....</b>	<b>\$1,415.00</b>

**4-Bar Suspension**

**As Shown**  
**\$1,415**